



# **DSPS**

## **DC input**

### **Switching Power Supply**

**Model ESA-FS350 400 460 500**

**ATX 12V type**



# TABLE OF CONTENTS

<b>INTRODUCTION .....</b>	<b>3</b>
<b>1. INPUT.....</b>	<b>3</b>
DC INPUT + 24VDC .....	3
<b>2. DC OUTPUT .....</b>	<b>3</b>
2.1 REGULATION .....	4
2.2 RIPLE & NOISE (NOT TO EXCEED).....	4
2.3 PROTECTION FUNCTIONS .....	4
2.4 RISE TIME TURN ON DELAY NORMAL LOAD.....	4
2.5 POWER GOOD SIGNAL .....	4
2.6 REMOTE SENSE .....	4
<b>3. BOOT START CONDITION .....</b>	<b>4</b>
<b>4. EFFICIENCY (TYPICAL) .....</b>	<b>4</b>
<b>5. COOLING.....</b>	<b>5</b>
<b>6. ENVIRONMENTAL.....</b>	<b>5</b>
6.1 TEMPERATURE RANGE .....	5
6.2 HUMIDITY: .....	5
6.3 ALTITUDE .....	5
6.4 VIBRATION ( NON-OPERATING) .....	5
<b>7. REGULATORY STANDARDS AND REQUIREMENTS .....</b>	<b>5</b>
7.1 SAFETY MEET .....	5
7.2 EMC MEET .....	5
<b>8. MEAN TIME BETWEEN FAILURE (MTBF) .....</b>	<b>5</b>
<b>9. MECHANICAL .....</b>	<b>6</b>
9.1 DIMENSIONS AND WIRING .....	6
9.2 ATX CONNECTORS OF OUTPUT WIRING.....	8
9.3 DC INPUT .....	8
<b>10. PACKING AND SHIPPMENT.....</b>	<b>8</b>
<b>11. NUCLEAR AND MEDICAL APPLICATIONS .....</b>	<b>8</b>
<b>12. TECHNICAL REVISIONS .....</b>	<b>8</b>
<b>13. GROUND ISOLATION CONFIGURATION.....</b>	<b>8</b>



Model ESA-FS Model Specification

**Introduction:**

This specification defines electrical performance and characteristic of DSPS Model ESA-FSIxxx series power supply. The DSPS Model ESA-FSIxxx was designed with reference to the Intel ATX power supply design guide ATX 12V Ver, 2.01 with a wide DC input and based on patented technology. The models are single DC +24V input without internal charger for normal IT equipment application.

**INPUT**

**DC INPUT +24VDC**

	Min.	rate	Max.	Units.
Vin Range	18	24	36	Vdc

**DC OUTPUT**

**Model : ESA-FSI350**

	+5V	+3.3V	+12V	-12V	-5V	+5VSB
A	20	20	23	0.8	-	2
Max	150W		270W**			
W	330W			9.6W		10W**

**Note:** Maximum total of output: 350W

**Model : ESA-FSI400**

	+5V	+3.3V	+12V	-12V	-5V	+5VSB
A	20	20	26	0.8	-	2
Max	150W		300W**			
W	380W			9.6W	**	10W**

**Note:** Maximum total of output: 400W

**Model : ESA-FSI460**

	+5V	+3.3V	+12V	-12V	-5V	+5VSB
A	22	22	28	0.8	-	2
Max	150W		330W**			
W	440W			9.6W	**	10W**

**Note:** Maximum total of output: 400W

**Model : ESA-FSI500**

	+5V	+3.3V	+12V	-12V	-5V	+5VSB
A	22	22	30	0.8	-	2
Max	150W		360W**			
W	480W			9.6W	**	10W**

**Note:** Maximum total of output: 500W



### 2.1 Regulation

	Min	Nom	Max	Unit
+5V	4.75	5.00	5.25	V
+3.3V	3.10	3.30	3.46	V
+12V	11.40	12.00	12.60	V
-12V	-10.80	-12.00	-13.20	V
+5V SB	+4.75	+5.00	+5.25	V

### 2.2 Ripple & Noise (not to exceed)

+5V	+12V	-12V	+5V SB		+3.3V
50mV	120mV	120mV	65mV		60mv

### 2.3 Protection Functions

#### 2.3.1 Over Power Protection

Total power protection: 110 ~130%

#### 2.3.2 Short Circuit Protection

Short to ground or cross with each output rails, the Power supply auto shut- down.

#### 2.3.3 Over Voltage Protection for +5V; +12V; +3.3V

Trip Voltage            5.74~7V;      13.4~15.6V; 3.76~4.3V

### 2.4 Rise Time Turn On Delay Normal Load

Rise Time (0.5V to 4.75V): < 17ms

### 2.5 Power Good Signal

Duration: 150ms - 500ms

### 2.6 Remote Sense

The +3.3V sense from pin13 of 24 pin plug.

### 3. Boot Start Condition

The DC voltage input must be larger than 20V.

### 4. Efficiency (typical)

Normal Mode: > 78% :full loading at 25°C @24Vdc input.



## Model ESA-FS Series Specification

### 5. COOLING

80x80x25 fans in the power supply, for 400, 460, 500 (dual fans)

### 6. ENVIRONMENTAL

The DSPS is capable of withstanding the following:

#### 6.1 Temperature range

Operating:..... 0°C to 45°C    100% loading

Storage:..... - 40°C to 65°C

#### 6.2 Humidity:

Operating:..... 85% non-condensing

Storage:..... 95% non-condensing

#### 6.3 Altitude

Operating:..... Up to 2000 meters (max)

Storage:..... Up to 4000 meters (max)

#### 6.4 Vibration (non-operating)

0.01g<sup>2</sup>/Hz at 5 Hz, sloping to 0.02 g<sup>2</sup>/Hz at 20Hz, and maintaining 0.02 g<sup>2</sup>/Hz from 20Hz to 500Hz. The area under the PSD curve is 3.13g RMS. The duration shall be 10 minutes per axis for all three axes on all samples.

### 7. REGULATORY STANDARDS AND REQUIREMENTS

#### 7.1 Safety

Refer to EN60950

#### 7.2 EMC meet:

EN 55022; EN55024 98; (A)

FCC part 15 Class A

### 8. MEAN TIME BETWEEN FAILURE (MTBF)

The calculated mean time between failures for the DSPS is greater than 100,000 hours when operate under the following conditions:

Ambient temperature: ..... 25°C

Loading:..... 75% rated load

The calculation refers to the Bellcore Technical Reference TR-TSY-000332, "Reliability Prediction procedure for Electrical Equipment".



# DSPS

## Model ESA-FS Series Specification

### 9. MECHANICAL

#### 9.1 Dimensions and Wiring

Standard P/S II dimension 86 x 150 x 140 mm Fan x 1 for ESA-FSI300-350.

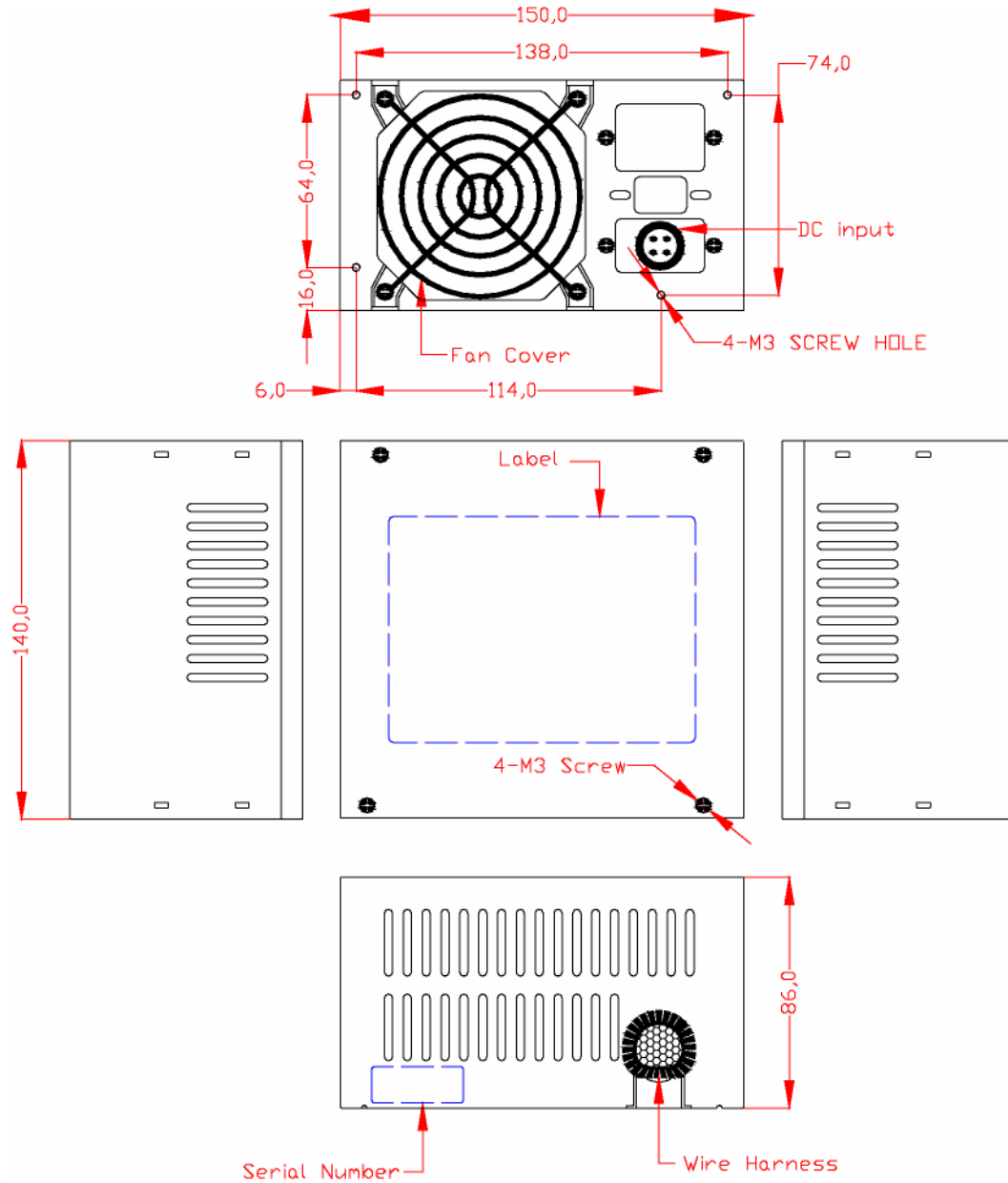

Fig. 1



# DSPS

## Model ESA-FS Series Specification

Standard P/S II dimension 86 x 150 x 140 mm Fan x 2 for  
 ESA-FSI400, 460, 500

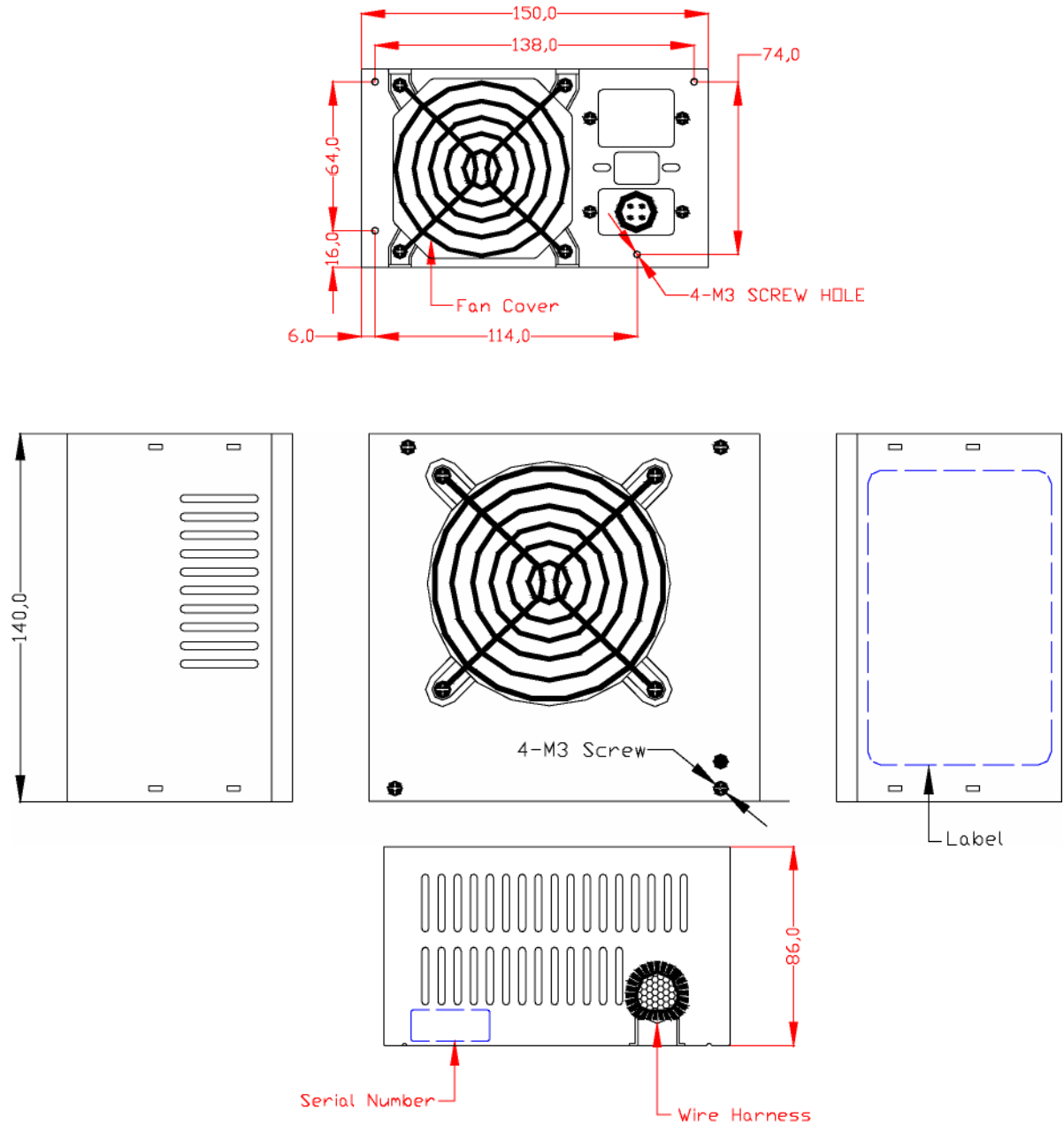

Fig. 1a



### 9.2 ATX Connectors of Output Wiring

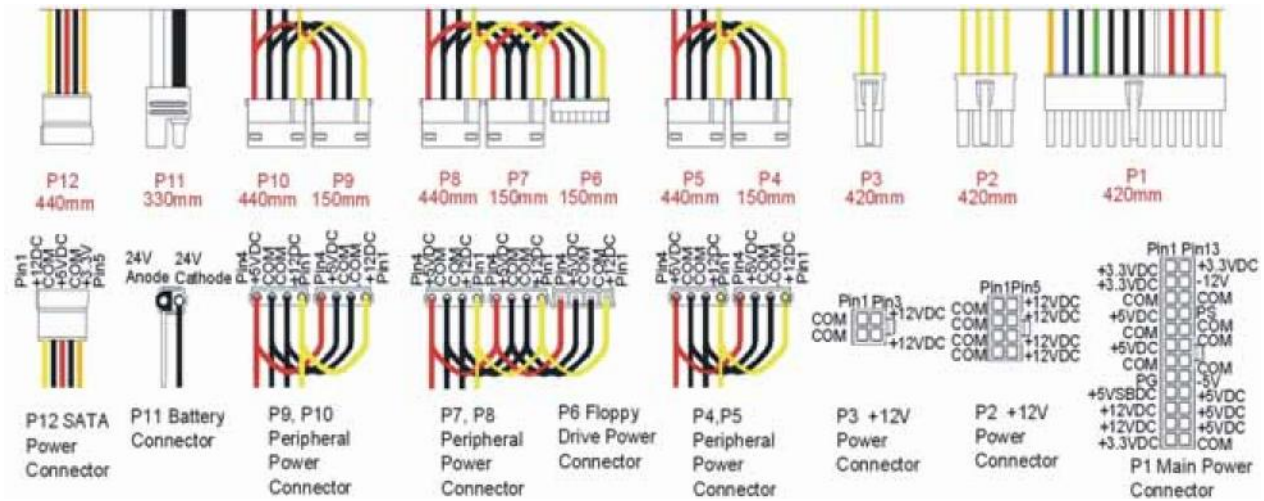

Fig. 2

Note: ESA-FSI350 should use a 20pin Main Connector

### 9.3 DC Input

At the front of the DSPS: 30Amps / 60V connector, or depending on customer requirement.

### 10. PACKING AND SHIPPING

Packing is adequate to provide protection against damage, breakage, or loss during shipment and is of the type that is not destroyed when opening. Standard industry OEM packaging: 10 pieces per Carton. Modified packaging requirements will be quoted on an individual basis.

### 11. NUCLEAR AND MEDICAL APPLICATIONS

DSPS products are not authorized for use as a critical component of life support systems, equipment used in hazardous environments or nuclear control systems without written approval.

### 12. TECHNICAL REVISIONS

The appearance of products, including safety agency certifications pictured on labels, may change depending on the date manufactured. The specifications are subject to change without notice. If the customer needs special function with features, the model can be modified to meet customer requirements.